

# ProtoDesign Inc.

50495 Corporate Dr. Suite 106 Utica MI. 48315

Phone: 586-739-4340 Fax: 586-739-4341

[www.teampdi.com](http://www.teampdi.com)

## INSTALLATION & OPERATING INSTRUCTIONS FOR THE FW CONTROL

Trained personnel should use this document as a guide to install the ProtoDesign feed water control. Follow necessary wiring practices as defined by the national electric code (NEC). Installation or selection of equipment should always be accompanied by trained technical personnel. Reset and probe wires runs should be separated from high voltage wire runs.

### SPECIFICATIONS:

**Ambient Operation Temp:** 0 to 150 degree F.

**UL Approval:** UL353 (operating control, non-limit)

**Supply Voltage:** 120/240/220/24 VAC 50/60 Hz.  
plus/minus 10% line variation.

**Contact Ratings:** SPDT, 10A, 1/3H.P. 120/240VAC.  
Rated 5 million cycles no load and 100,000 cycles rated load.

**Power Consumption:** 1.5VA

**Wiring Terminals:** Optional 8-Pin Plug-in Module socket, all connections are #6-32 screws with pressure clamps. Open board design 1/4" quick connects on high voltage and 3/16" quick connects on low voltage.

**Probe wire distances:** 500 feet maximum using MTW or THHN #14 or #16 AWG wire.

### FEATURES:

**Sensitivity:** 26K (Standard)

**Falling level time delay:** 0 to 60 seconds in 1 second increments.

**Rising level time delay:** 0 to 60 seconds in 1 second increments.

**Relay energized indicator:** LED indicates that the relay is energized.

### OPERATION

**Single Level Service - Direct Mode:** When the liquid rises to the high probe electrode on terminal **TB3**, the control energizes (LED will be lit). The control remains energized until the liquid leaves the electrode de-energizing the load contacts (LED will not be lit).

**Single Level Service - Inverse Mode:** Same as "Direct Mode" except that when the liquid contacts the high probe electrode, the contacts de-energize (LED will not be lit). When the liquid leaves the electrode the control energizes (LED will be lit).

**Differential Service – Direct Mode:** When the liquid rises to the high probe electrode on terminal **TB3**, the control energizes (LED will be lit). The control remains energized until the liquid leaves the low probe electrode on terminal **TB4** de-energizing the load contacts (LED will not be lit).

**Differential Service – Inverse Mode:** Same as "Direct Mode" except that when the liquid contacts the high probe electrode, the contacts de-energizes (LED will not be lit). When the liquid leaves the low probe electrode the control energizes (LED will be lit).

**Time Delays:** In Differential Service, rising level time delays begin upon liquid level contacting the high probe and falling level time delays begin upon leaving the low probe. In Single Level Service that uses the high probe and requires time delays on increasing and decreasing levels, terminals **TB3** (high) & **TB4** (low) must be jumpered together. Otherwise, Single Level Service time delay will only be on decreasing level.

### Maintenance Schedule

- Inspect probe annually for scale build-up and clean if necessary. Make certain there is no scale or build-up on the probe or its white insulator.
- Replace probe every 10 years. More frequent replacement of the probe is required if it is used in locales where significant water treatment is required, where more frequent cleaning is necessary, or in applications with high make- up water requirements.
- Replace the feed water control every 15 years or after 100,000 cycles on the relay.

## DIMENSIONAL DRAWING

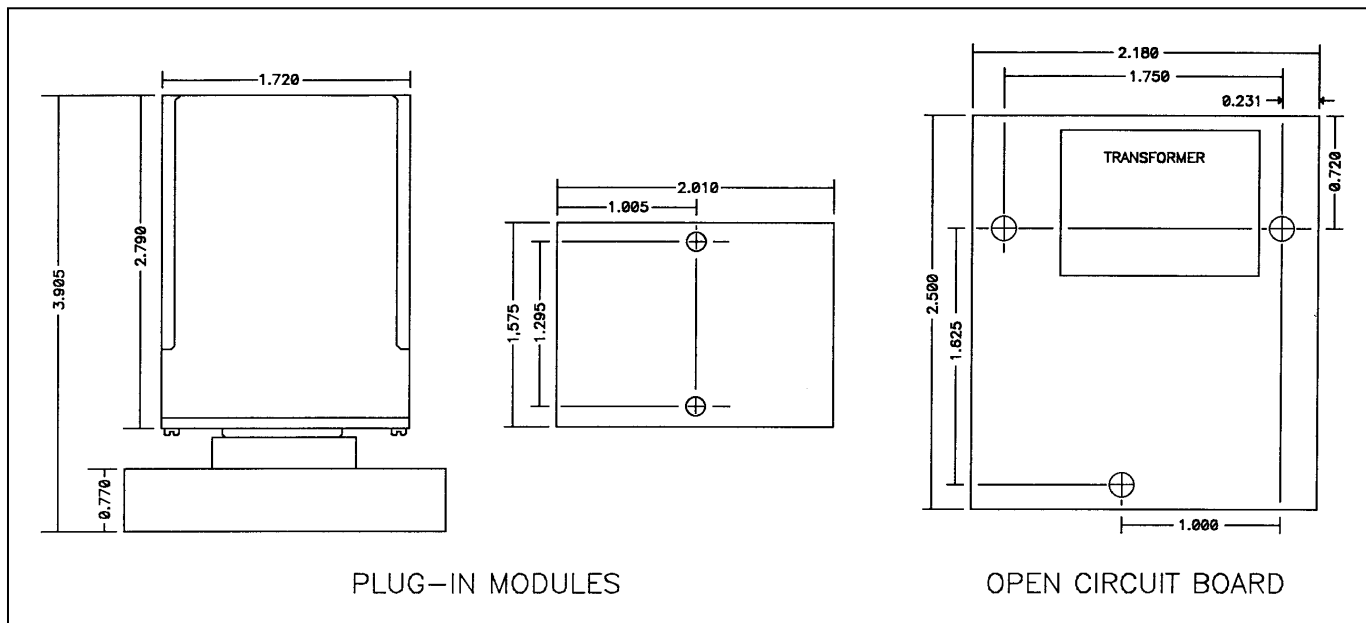

## TYPICAL WIRING DIAGRAM

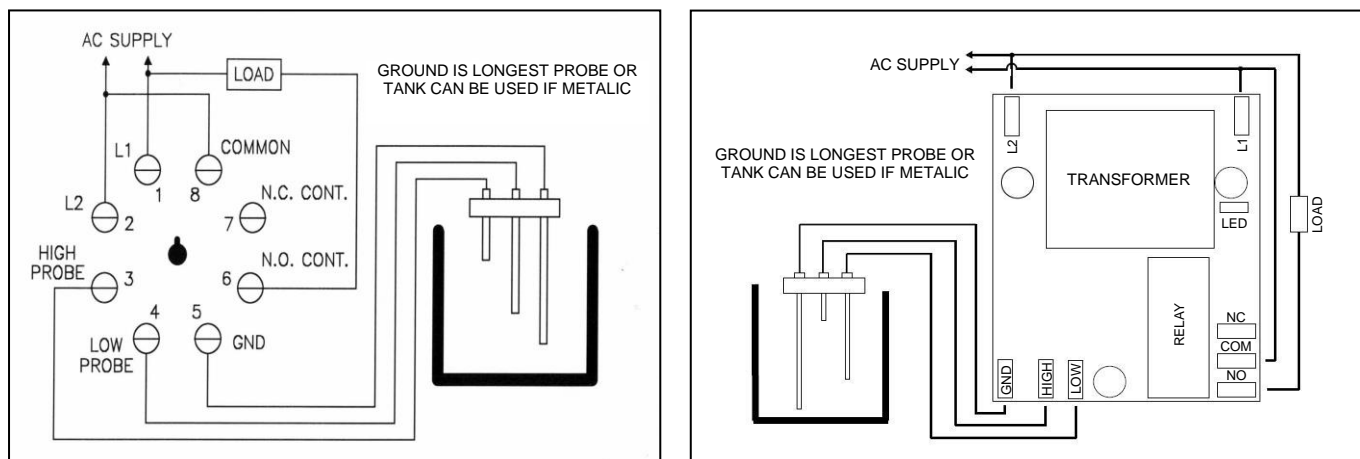

## MODEL NUMBER DESIGNATION

**FW - X - X - X - X - XX - XX - X** — **OPTIONAL CHARACTER (any combination):**

Blank, C=Conformal Coating, D=RoHS

**FALLING LEVEL DELAY:**

00 SECONDS (Standard), 01 - 60 SECONDS (optional in 1 second increments)

**RISING LEVEL DELAY:**

00 SECONDS (Standard), 01 - 60 SECONDS (optional in 1 second increments)

**MODE:**

A = DIRECT, B = INVERSE (Standard)

**SUPPLY VOLTAGE:** 1 = 120VAC (Standard), 2 = 240VAC, 3 = 220VAC, 4 = 24VAC

**SENSITIVITY:**

C = 26K (Standard), (contact factory for other sensitivity options)

**PACKAGE:**

- 1 = 8 PIN MODULE
- 2 = OPEN BOARD WITH STANDOFFS FOR 1/8" PANEL
- 3 = OPEN BOARD WITH STANDOFFS FOR 1/16" PANEL (Standard)

**MODULE SOCKET:** LCS - 8 = (FW SOCKET)